

Chetak

4 STROKE
USA



MODEL NO.: 003002CL

NOTICE

All information contained in this manual is based on the latest product information at the time of publication. Bajaj Auto Ltd. accepts no liability for any inaccuracies or omissions in this publication, although every possible care has been taken to make it as complete and accurate as possible. All procedures and specifications subject to change without prior notice. The right is reserved to make such changes at any time without prior notice and without incurring an obligation to make such changes to product manufactured previously. Contact your authorized Bajaj Dealer for the latest information on product improvements incorporated after this manual was issued.

DOC. NO.: 36020252

REV. 00, MAR 02

INDEX

Sr. No.	Description	Page No.
1.	Identification Data	1
2.	Salient Features	2
3.	Technical Specifications	3
4.	Location of Parts & General Information	4-8
5.	Periodic Maintenance Chart	9
6.	Check and Adjustments during P.D.I., 1st, 2nd, 3rd, 4th & 5th Servicing	10
8.	Tightening Torques - Engine	11
9.	Tightening Torques - Chassis	12
10.	Engine Exploded View	13
11.	Service Data - Engine	14
12.	Service Data - Chassis	15
13.	Dismantling and Assembly : Handle Bar	16
14.	Electricals : Maintenance & Checking	17-20
15.	Electrical Wiring Diagram	

Downloaded from www.ScooterTime.net

IDENTIFICATION DATA

The chassis and engine serial numbers are used to register the vehicles. They are the only means of identifying your particular vehicle from the other of the same model and type. These serial numbers may be needed by your dealer when ordering the parts. In the event of theft, the investigating authorities will require both these numbers in addition to the model, type and any special features of your vehicle that can help identification.

Serial numbers with prefix **CLC** and **CLE** are stamped on chassis and engine of the vehicle in the position indicated in the figures.

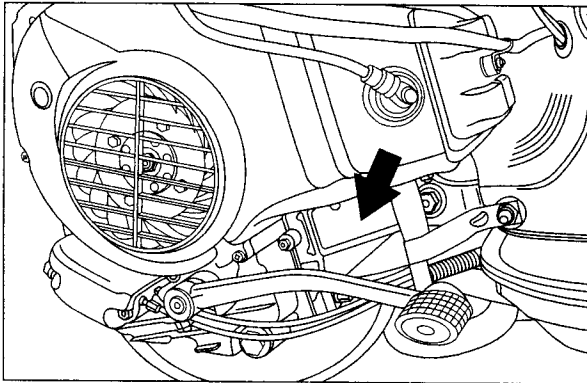

Engine Number

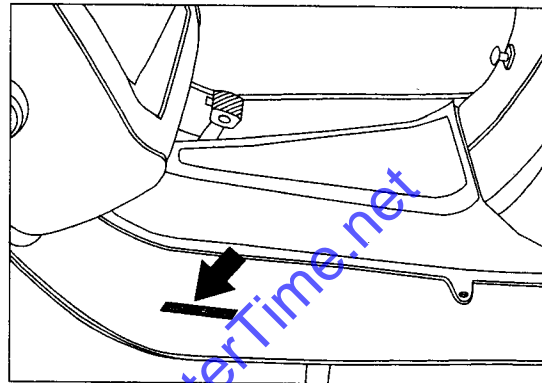

Chassis Number

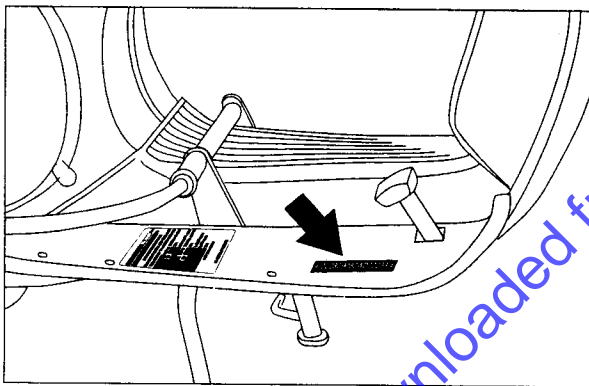

VIN Number

The chassis and engine numbers serial numbers are used by the factory to identify your particular vehicle. Always quote these numbers when ordering parts or when making inquiry with regard to service operations. The vehicle is identified by the Department of Motor Vehicles in your state by the Vehicle Identification Number. It is a crime in all states to alter any of these numbers.

Downloaded from www.ScooterTime.net

SALIENT FEATURES

Style and Looks

- Classic styling.
- Attractive speedometer.

Performance

- The 4 Stroke technology, fuel efficiency and fuel economy are combined in the new Bajaj 150 cc Chetak engine.
- Bigger foam air filter for air purification and better volumetric efficiency and strong guard for dust sealing.
- TRICS (Throttle Regulated Ignition Control System) technology for better combustion of fuel at all engine speed.
- Bigger oil strainer provided for thorough filtration of engine oil to increase life of engine components.

Convenience

- Fuel gauge & Manual fuel valve with reserve position.
- Safety ignition cut-off.

Comfort

- Stylish thick foam seat for riding comfort.
- Proven anti-dive suspension with variable rate coil spring shock absorber for positive & safe control.
- Adjustable rear shock absorber for easy selection according to road condition and load.

Safety

- Lockable petrol tank.
- Pedal type rear brake for quick stop.

Downloaded from www.ScooterTime.net

TECHNICAL SPECIFICATIONS

Engine & Transmission

Type	: Four stroke, Forced air cooled
No. of cylinders	: One
Bore	: 57.00 mm
Stroke	: 57.00 mm
Engine displacement	: 145.45 cc
Maximum net power	: 9.00 HP at 6000 rpm
Maximum net torque	: 8.31 Lb-Ft at 4000 rpm
Compression pressure	: 12 ± 1 kg/cm ² (170.64 ± 14.22 psi)
Compression ratio	: 9.3 ± 1
Idling speed	: 1200 ± 150 rpm
Ignition system	: C. D. I.
Fuel	: Unleaded Petrol (87 Octane)
Carburetor	: Keihin PB 20
Spark plug	: Champion PL 7 YC
Spark plug gap	: 0.6 to 0.7 mm
Lubrication	: Wet sump, forced lubrication
Starting	: Kick start / Electric start
Clutch	: Wet, multidisc type.
Transmission	: 4 speed constant mesh
Overall gear ratios	:
First gear	: 17.33 : 1
Second gear	: 10.82 : 1
Third gear	: 7.43 : 1
Fourth gear	: 6.10 : 1
Primary gear ratio	: 2.75 : 1

Chassis and Body

Frame type	: Monocoque construction
Suspension	:
Front	: Leading link Anti-dive, variable rate coil spring & double acting shock absorber
Rear	: Variable rate coil spring & double acting shock absorber
Brake type	:
Front & Rear	: Mechanical expanding shoe friction type
Brake size	:
Front	: 150 mm dia / 5.91"
Rear	: 130 mm dia / 5.12"
Tires	:
Front	: 3.50 X 10, 4 P.R.
Rear	: 3.50 X 10, 4 P.R.
Tire pressure	:
Front	: 1.25 kg/cm ² (18 Psi)
Rear (without pillion)	: 1.75 kg/cm ² (25 Psi)
Rear (with pillion)	: 2.50 kg/cm ² (36 Psi)
Fuel tank capacity	: 1.32 Gal. (5 litres)

Controls

Steering	: Handle bar
Accelerator	: Twist grip type on right hand of handle bar
Gears	: Twist grip type on left hand of handle bar
Clutch	: Lever operated on left side of handle bar
Brakes	:
Front	: Lever operated on right side of handle bar
Rear	: Pedal operated by right foot

Electricals

System	: 12 Volts, DC
Battery	: 12V- 9Ah
Head lamp	: 35/35 W
Tail/stop lamp	: 5 / 10 W
Side indicator lamp	: 10 W
Horn	: 12V, DC

Dimensions

Length	: 1825 mm / 71.85"
Width	: 685 mm / 26.97"
Wheel base	: 1275 mm / 50.20"
Height	: 1150 mm / 45.28"
Saddle height	: 805 mm / 31.69"

Weights

Curb weight	: 115 kg / 253 lbs
Max.total weight (including driver)	: 195 kg / 430 lbs

Performance

Maximum speed	: 90 km/h / 55 mph with 68 kg/150 lbs (single rider) payload
Climbing ability	: 25.0 % max.

Notes

- All dimensions are under unladen condition.
- Above information is subject to change, for the latest information please contact Service dept.

LOCATION OF PARTS & GENERAL INFORMATION

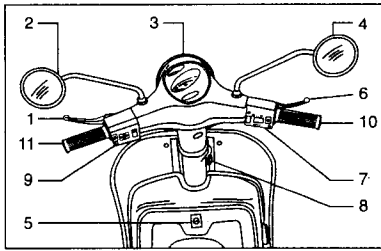

Handle Bar

- | | |
|---------------------|------------------------------------|
| 1. Clutch Lever | 7. RH Switch |
| 2. Mirror LH | 8. Steering Lock / Ignition Switch |
| 3. Speedometer | 9. LH Switch |
| 4. Mirror RH | 10. Accelerator |
| 5. Luggage box lock | 11. Gear Shifter |
| 6. Fr. Brake Lever | |

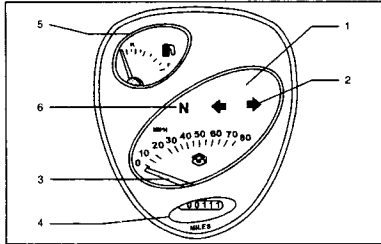

Speedometer

- Hi-Beam Indicator
- Turn Signal Indicators Left & Right
- Speedometer
- Odometer
- Fuel Gauge
- Neutral Indicator

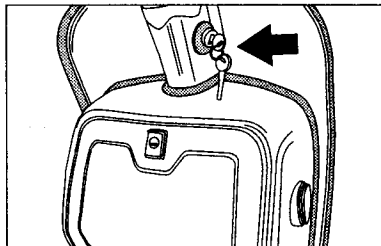

Steering Lock/Ignition Switch

The Steering Lock / Ignition Switch is located on the right hand side below the handle bar. It has three positions.

Key Position	Function	Key Removal
LOCK	Steering locked Ignition OFF	Key can be removed
OFF	Steering unlock Ignition OFF	
ON	Ignition ON	Key can not be removed

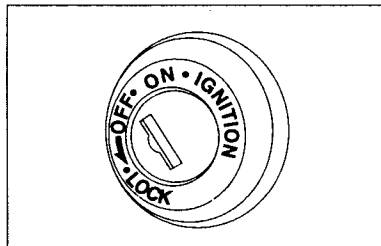

Steering Lock

To Lock the Steering

- Turn the handle bar to the left. (Steering will be locked only when handle bar is in left position.)
- With the key in OFF position, push down and turn it to the lock position.
- Take out the key.

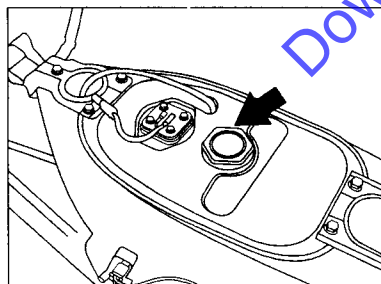

Fuel Tank

Fuel Tank

- It has capacity of 1.32 gal.
- Location of fuel tank is as shown in the figure.

Warning: Never mix oil in the gasoline. To do so can lead to engine failure and subsequent accident with potentially serious injury or even death. Use only unleaded gasoline of research octane number 87 or higher.

There is serious danger of fire if gasoline is leaking from any portion of your vehicle. Never ride your vehicle if you smell gasoline. Have your vehicle repaired immediately by your authorized Bajaj dealer. Failure to heed this warning can lead to a serious fire, with subsequent serious injury or even death.

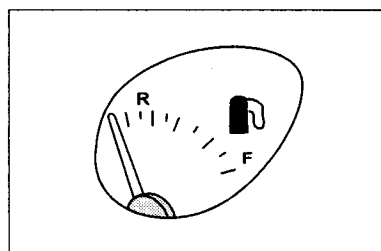

Fuel Gauge

Fuel Gauge

The fuel level gauge is provided in the speedometer console to indicate the fuel quantity in the fuel tank.

Fuel level is indicated as follows:

- "E" mark indicates approx. Empty.
- Mid mark indicates approx. 0.66 gal.
- "F" mark indicates approx. 1.32 gal.

LOCATION OF PARTS & GENERAL INFORMATION

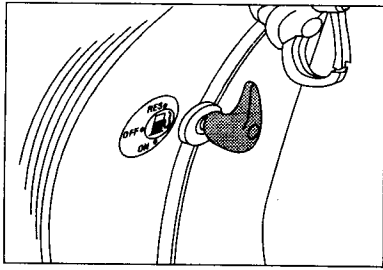

Fuel Cock Position

Fuel Cock

It has the following three positions

On : When fuel level is above 0.26 gal.

Res : When fuel level drops below 0.26 gal.

Off : Fuel supply is cut off.

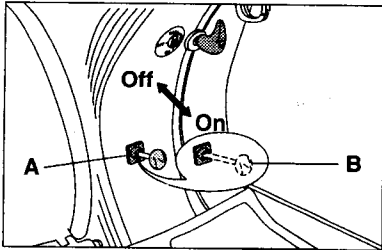

Choke Lever

Choke Lever

- It is located near the fuel cock lever.

- Choke is required especially for cold starting.

- The 'On' and 'Off' positions of choke lever are as shown in figure.

A : Choke "OFF"

B : Choke "ON"

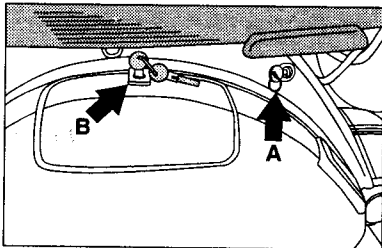

A: Seat lock B: Tool box lock

Seat Lock

- It is located on left hand side of the seat.

- The lock ensures the security of the fuel tank.

- Turn the key clockwise to unlock seat.

- For locking, gently press the seat from top.

Tool Box Lock: Tool Box Lock is located as shown in the figure B.

Tool Kit: Tool kit is kept inside the Tool Box which can be locked with the ignition key.

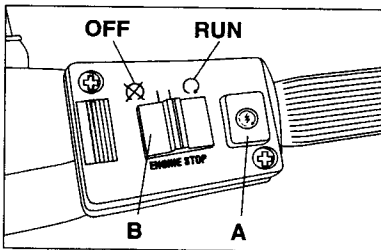

Right Hand Switch

Right Hand Switch

A Starter switch. Press the button to start the engine.

B Supplementary engine stop switch : Move to the 'Run' position before starting engine. Move to the 'Off' position to stop engine.

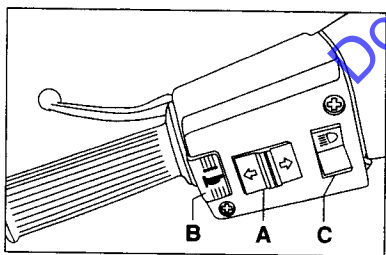

Left Hand Switch

Left Hand Switch

This scooter is equipped with lights that illuminate whenever the ignition is turned on.

A Turn signal switch : Move the knob left or right to activate turn signal. Move back the knob to center position to cancel turn signal.

B Horn Switch : Press to activate horn.

C Headlight High/Low beam switch. Press the toggle upward for high beam, press the toggle downward for low beam.

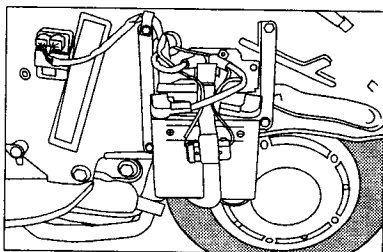

Battery

Battery (12V - 9Ah)

- Battery is located at LH side inside the Cowl.

- Check & ensure that the electrolyte level is between the upper and lower level lines in each cell.

- If the electrolyte level is below the lower level in any cell, fill to upper level with **distilled water only**.

- Inspect the terminals. Clean if corroded. Tighten the battery clamps, then apply a little petroleum jelly.

- **Ordinary tap water is not a substitute for distilled water and will shorten the life of the battery.**

LOCATION OF PARTS & GENERAL INFORMATION

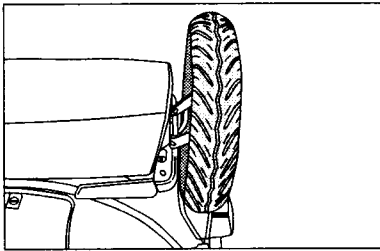

Spare Wheel

Spare Wheel

Spare wheel is located behind seat on bracket. For removing the wheel

- Remove the wheel cover.
- Remove the spare wheel mounting bolts. (Ref. fig.)

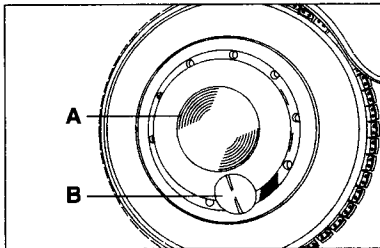

Wheel Cover

Wheel Cover

The wheel covers are fitted to all wheels. A cap is provided on the wheel covers. Remove the cap to check or adjust tire pressure. (Ref. fig.)

- A: Wheel Cover
- B: Cap

Warning: Proper tire pressure is very important to the handling of your scooter, and to your safety. Never ride your scooter with tires either over or under-inflated. See the specifications table on page 12. Failure to observe this warning can lead to instabilities in handling and an upset with subsequent serious accident, injury, or even death.

Note: Rear brake liner wear can be inspected through window on rear brake drum by unscrewing the plug on it.

Front brake liner wear can be inspected by looking at the wear indicator on front brake actuating lever.

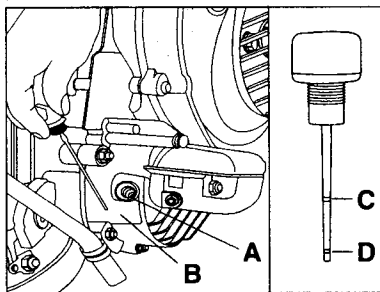

Engine Oil

- A: Oil Filler Hole
- B: Oil Level Indicator
- C: Upper Level
- D: Lower Level

Engine Oil: Check engine oil level daily.

For proper functioning of cylinder block/piston, crankshaft, tappets, clutch and transmission, the oil should be maintained at an appropriate level.

- Place the vehicle on center stand, on a level ground.
- Clean the surface area around the oil filler opening.
- Unscrew the dipstick from oil filler opening hole and wipe it dry.
- Put the dip stick on oil filler opening,

take out the dip stick and observe the oil level on it.

- There are two marks engraved on it. If the level is below the lower level mark, top up with the appropriate qty. of recommended oil up to upper level mark. If the oil level is too high i.e. above the upper level mark, drain some oil from drain hole.
- Fit back the dipstick and tighten it securely.
- Ensure that there is no oil leakage.

Recommended oil : SAE 20W40

Oil capacity : 1 Quart

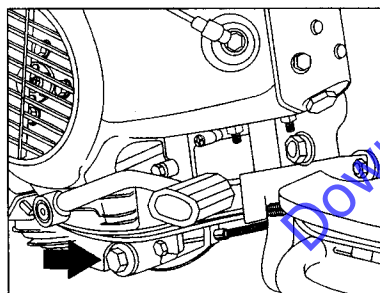

Location of Oil Filter

Oil Filter Cleaning

- Oil filter is situated inside the bolt as shown in the figure.
- Oil filter should be cleaned in accordance with lubrication chart by an **Authorized Bajaj Dealer.**

Warning: Failure to ensure that your engine has the proper amount of the appropriate grade oil can lead to an engine seizure, with subsequent upset, serious injury, or even death.

Always ensure that your scooter has the proper amount and type of oil.

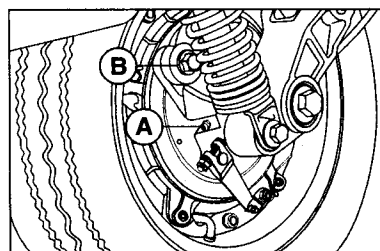

Antitive front suspension

Lubrication of the antitive front suspension

A grease nipple is provided on Brake panel at location "A" (Ref. fig.) for lubrication of brass bushes fitted inside Front brake panel assly. These bushings are recommended to be greased after every 2000 miles.

To lubricate the inner bushing fitted inside Antitive link assly at location "B" (Ref. fig.), you will have to dismantle and remove the bushing and then lubricate with Grease. The inner bushings should be greased after every 3000 miles.

Location	Operation	Recommended Interval
"A"	Lubricate through the grease nipple.	Every 2000 miles
"B"	Dismantle, Remove Bush inner and then lubricate with grease.	Every 3000 miles

LOCATION OF PARTS & GENERAL INFORMATION

Spark Plug

- Using compressed air, blow any loose dirt away from around the spark plug.
- Remove the spark plug using the special spark plug wrench, clean the spark plug using a wire brush, or a proprietary spark plug cleaner.
- Adjust the gap if incorrect by bending the outer electrode carefully.

Caution

Never try to bend the center electrode of the spark plug. This will surely destroy your spark plug.

Spark Plug Gap : 0.6 to 0.7mm

Spark Plug : Champion PL 7 YC

(To be used with a resistance spark plug cap)

Starting Procedure (Kick Start)

- Ensure the transmission is in neutral.
- Ensure the Steering/Ignition lock is in the 'ON' position.
- Ensure the Engine stop switch is in the 'RUN' position.

How to operate the kick starter :

Move the kick-starter slowly. Make sure that the ratchet is engaged, then depress smartly.

A) Normal Starting:

Do not open throttle while starting. If the engine fails to start, slightly open the throttle (not more than $\frac{1}{4}$ turn) before depressing the kick-start lever.

B) Cold Starting: Use the Choke only for cold starting.

Pull the choke lever and depress the kick-starter lever. Do not open the throttle while using the choke. Release the choke lever to the 'OFF' position once the engine has warmed up.

- **Never rev the engine to higher RPMs immediately.**
- **Moving from 'Stand Still Position'**
Pull the clutch lever to its full travel and twist the shift lever tube clockwise in one smooth motion to put the vehicle in 1st gear. Release clutch gradually and simultaneously, open the throttle gradually to move away from stand still position.
- Do not run the vehicle with the clutch partially engaged. Do not slip the clutch to overtake or to climb on a gradient. This will damage the clutch.
- **Downshifting of gears i.e. Shifting from 4th to 3rd to 2nd to 1st gear:**
Reduce the speed of the vehicle. Pull the clutch lever completely and twist the gear lever upwards and release the clutch lever gradually and increase throttle. For further ease of gear shifting slightly open the throttle momentarily while pulling the clutch lever and then twist the gear lever upwards.

- **Do not keep the clutch lever depressed in neutral while waiting at the traffic signals.** This will result in difficult gear shifting as the gear box is constant mesh type which requires rotation of gears for ease of engagement.

Warning: Do not tilt the vehicle toward the LH side. Engine oil may flow out of through the crankcase breather tube, to air cleaner, lowering the oil level in the crankcase. Also, should the vehicle be allowed to fall accidentally on its left side, ensure that the oil level is correct after picking the scooter up and placing it on the stand. Failure to observe this warning could lead to engine seizure with subsequent upset, serious injury, or even death.

Battery electrolyte may also leak out from the cells, if the vehicle happened to fall on its left side. Electrolyte being acid, can damage painting and rubber components. Spilled acid around the battery area may be cleaned with water and baking soda to neutralize the acid.

Tire Pressure

Always maintain the tire pressure as indicated in the table below.

Warning

Failure to maintain proper tire pressure can lead to instabilities in handling with subsequent upset, serious injury, or even death.

Tire Size

3.50 - 10 (All three tires)

Front		18 psi / (123 kPa)
Rear	Solo	25 psi / (175 kPa)
	With passenger	36 psi / (245 kPa)

After starting or in neutral gear.

If the engine is revved to higher RPMs immediately after starting it may lead to severe engine damage as lubricating oil take some time to reach all the components.

Starting Procedure (Electric Start)

- Ensure the transmission is in neutral.
- Ensure the Steering/Ignition lock is in the 'ON' position.
- Ensure the Engine stop switch is in the 'RUN' position.
- Press the starter button to start the engine. Release the starter button as soon as the engine starts.
- When the engine is cold, place the choke lever 'ON', press the starter button with the throttle completely closed.
- When the engine has warmed up release the choke lever to the 'OFF' position.

LOCATION OF PARTS & GENERAL INFORMATION

Running In

- First 1200 miles is designated as a running in period. The maximum vehicle speed recommended during running in:

Distance in miles	Max. vehicle speed in gears (mph)			
	1st	2nd	3rd	4th
0 - 1200	10	20	30	40

- Never exceed the specified running in speed.
- Do not over-rev the engine.
- Do not start moving or race the engine immediately after starting. Run the engine for a minute at idle speed to give the oil a chance to work up into the engine.
- Never let the engine lug, that is, run at slow RPMs with wide-open throttle during the running-in period.

Warning: You must run-in your vehicle according to this running-in schedule if your scooter is to achieve its maximum life and most reliable service. Further, immediately running the engine hard could lead to an engine seizure with subsequent upset, serious injury, or even death.

Fuel Saving Tips

A well maintained vehicle can contribute a lot to the saving of petrol. Following are a few simple tips for keeping your vehicle healthy.

Good riding habits

- Ride smoothly and steadily.
- Sudden stops & start are hard on the engine & equipment.

- Don't overload the vehicle above the specified payload.
- Use the accelerator judiciously. Think of the accelerator as fuel cock. The more you will turn it, the more gasoline will be consumed.
- Cut off the engine if you want to stop more than for two minutes. Remember, idling costs fuel.

Vehicle Condition

- Check all fuel lines and connections whenever your vehicle smells of gasoline. Never fill the gasoline right up to the filler cap.
- Always maintain the recommended tire pressure and check it every week. Under-inflated tires increases rolling resistance and thus costs both fuel and tire life.
- Ensure that the brakes are not dragging/binding.
- For keeping the engine healthy
 - Inspect and clean the spark plug, adjust the gap.
 - Clean the air filter.
 - Service carburetor and adjust idling speed.
 - If there is a power loss, then contact an authorized Bajaj dealer and get the vehicle properly tuned.

Regular maintenance will save fuel and money assuring you trouble free, enjoyable and safe riding.

PERIODIC MAINTENANCE CHART

The maintenance and adjustments outlined in this section are easily carried out and must be done in accordance with the periodic maintenance chart to keep the vehicle in good running condition. The initial maintenance is vitally important and must not be neglected.

S.N.	OPERATION	FREQUENCY	WHICHEVER COMES FIRST				ODOMETER READING (MILES)			
			EVERY	300	1200	3000	6000	9000	12000	15000
1.	Servicing		●	●	●	●	●	●	●	
2.	Engine oil : Replacement		■	■	■	← Every 3000 miles →				
3.	Oil strainer cleaning		●	●	●	← Every 3000 miles →				
4.	Air filter element cleaning * **	3000 miles			●	●	●	●	●	
5.	Spark plug : Cleaning/gap setting ** : Replace	6000 miles	●	●	●	●	●	●	●	
6.	Carburetor cleaning/overhaul **				●	●	●	●	●	
7.	Fuel line/Fuel filter element cleaning Fuel filter replacement if required	6000 miles	●	●	●	●	●	●	●	
8.	Check & adjust valve clearance **		●	●	●	●	●	●	●	
9.	Control cables adjustment		●	●	●	●	●	●	●	
10.	Tightening nuts/bolts/fasteners	Month	●	●	●	●	●	●	●	
11.	Check functioning of all electrical components	Day	●	●	●	●	●	●	●	
12.	Head lamp alignments - check & adjust		●	●	●	●	●	●	●	
13.	Tire rotation	6000 miles								
14.	Tire pressure	Week	●	●	●	●	●	●	●	
15.	Steering column : check and adjust				●	●	●	●	●	
16.	Front/rear brake : inspection/adjust : Overhaul		●	●	●	●	●	●	●	
17.	Check battery electrolyte level	Month	●	●	●	●	●	●	●	
	Apply petroleum jelly on battery terminals	Month	●	●	●	●	●	●	●	
18.	Lubricate a. Front & rear brake lever b. Gear shifter c. Speedo pinion/gears/cable d. Brake cam shafts e. Stand pivot f. front fork bearing races/balls g. wheel bearings h. front suspension	After washing the vehicle	□	□	□	□	□	□	□	

Refer Page No. 6

- Indicates operation to be performed.
- Indicates lubrication by SAE 20W40 API SJ grade oil.
- Indicates lubrication by Lithium-calcium soap base grease.
- * To be cleaned more frequently in dusty area.
- ** Must be performed to maintain emissions warranty.

PRE-DELIVERY INSPECTION CHART

Sr. No.	Operation to be carried out	P.D.I.	1st	2nd	3rd	4th	5th
1	Wash and clean the vehicle on receipt		●	●	●	●	●
2	Check and correct tire inflation pressure including that of spare wheel	●	●	●	●	●	●
3	Check all nuts and bolts for tightness especially handle bar bolt, engine foundation bolt, shock absorber nuts and wheel nuts etc.	●	●	●	●	●	●
4	Check engine oil level and top up, if necessary	●		●			
5	Flush and refill engine oil		●		●	●	●
6	Remove and clean air cleaner filter element		●	●	●	●	●
7	Clean spark plug, adjust the gap and refit		●	●	●	●	●
8	Clean the carburetor / adjust idling speed				●	●	●
9	Check & adjust valve clearance		●	●	●	●	●
10	Carry out lubrication as per lubrication chart		●	●	●	●	●
11	Check steering-cum-ignition lock & other lock for proper operation	●					
12	Check for smooth operation of choke lever and accelerator	●					
13	Check front & rear brakes for efficient working	●	●	●	●	●	●
14	Check and adjust steering	●				●	
15	Check all lights, horn, switches, speedometer for satisfactory working	●	●	●	●	●	●
16	Initial charging of battery. Install & apply petroleum jelly on terminals		●	●	●	●	●
17	Check battery electrolyte level & supply petroleum jelly on terminals		●	●	●	●	●
18	Test drive the vehicle	●	●	●	●	●	●
19	Repair for any other defects seen or observed during test drive	●					
20	Clean the vehicle before delivery	●	●	●	●	●	●

TIGHTENING TORQUES ENGINE

Sr. No.	Part Name	Lb-Ft	Torque - Kgm.
	Engine		
	Nuts for:		
1	Crankcase to Crankcase (Qty. 5)	10.85 - 13.02	1.5 to 1.8
2	Gear shifter housing (Qty. 2)	9.40 - 10.85	1.3 to 1.5
3	Cylinder head (Qty. 4)	14.47 - 15.91	2.0 to 2.2
4	Crankshaft clutch side (Gear primary spur)	65.10 - 68.71	9.0 to 9.5
5	Crankshaft magneto side (Rotor nut)	39.78 - 43.0	5.5 to 6.0
6	Intermediate shaft (For clutch assly)	65.10 - 68.71	9.0 to 9.5
7	Tappet	5.79 - 7.23	0.8 to 1.0
8	Main shaft	36.15 - 39.78	5.0 to 5.5
9	Cover to crankcase	9.40 - 10.85	1.3 to 1.5
10	Silencer to cylinder head	14.47 - 18.07	2.0 to 2.5
11	Crankcase to crankcase (Qty. 2)	9.40 - 10.85	1.3 to 1.5
12	Kick lever	14.47 - 18.07	2.0 to 2.5
	Bolts for:		
13	Cylinder head to cylinder block (Qty. 2)	6.5 - 7.95	0.9 to 1.1
14	Silencer to crankcase (Qty. 1)	21.69 - 25.30	3.0 to 3.5
15	Cam shaft sprocket	5.78 - 7.23	0.8 to 1.0
16	Cam chain tensioner adjuster	5.78 - 7.23	0.8 to 1.0
17	Manifold to cylinder head	4.33 - 5.78	0.6 to 0.8
18	Chain tensioner body	4.33 - 5.78	0.6 to 0.8
19	Cover to crankcase	9.40 - 10.85	1.3 to 1.5
20	Oil drain bolt	18.80 - 21.69	2.6 to 3.0
	Screws for:		
21	Stator plate	4.33 - 5.78	0.6 to 0.8
22	Screw for oil tube assly	2.17 - 2.90	0.3 to 0.4
23	Stopper plate (Cylinder head)	4.33 - 5.78	0.6 to 0.8
24	Gear shifter cover	4.33 - 5.78	0.6 to 0.8
25	Gear kick (Qty. 2)	4.33 - 5.78	0.6 to 0.8
	General:		
26	Spark plug	18.07 - 21.69	2.5 to 3.0
27	Cap (Cylinder head)	5.78 - 7.23	0.8 to 1.0
28	Oil plug	18.80 - 21.69	2.6 to 3.0

TIGHTENING TORQUES CHASSIS

Sr. No.	Part Name	Lb-Ft	Torque - Kgm.
	Chassis		
	Nuts for:		
1	Front shock absorber	21.69 - 25.30	3.0 to 3.5
2	Fuel cock asslt on fuel tank	21.69	3.0
3	Engine link mounting on chassis	21.69 - 28.92	3.0 to 4.0
4	Engine mounting on link	25.30 - 28.92	3.5 to 4.0
5	Pivot securing wheel hub	36.15 - 39.78	5.0 to 5.5
6	Wheel assly on brake drum (Qty. 5)	14.47 - 19.52	2.0 to 2.7
	Bolts for		
7	Handle bar mounting	23.14 - 27.47	3.2 to 3.8
8	Rear shock absorber to engine	14.47 - 16.63	2.0 to 2.3
9	Front mudguard	1.81 - 2.17	0.25 to 0.3
10	Stand	2.90 - 3.61	0.4 to 0.5
	Steering		
11	Upper bearing race	4.34 - 5.06	0.6 to 0.7
12	Ring nut	36.15 - 43.38	5.0 to 6.0

Downloaded from www.ScooterTime.net

ENGINE EXPLODED VIEW

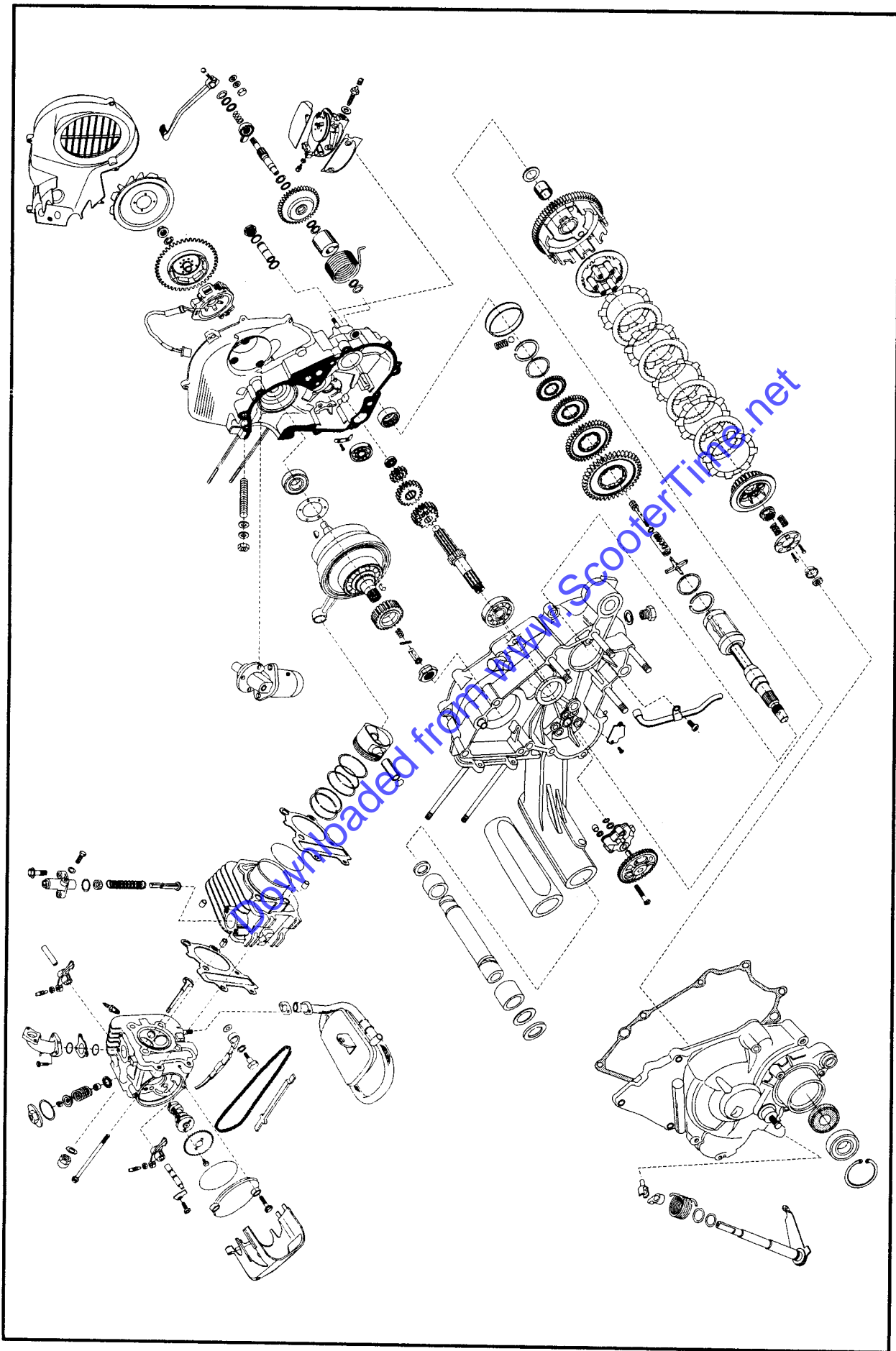

SERVICE DATA ENGINE

Sr. No.	Description	Standard	Remark
1	Carburetor: Make & Type Main jet Main air jet Pilot jet Jet needle Jet needle clip position Float height Air screw setting (From fully closed position)	Keihin PB20 108 90 42 OB 4 3 rd from top 10.7 mm 2.25 ± 0.25 turns	
2	Cylinder head: Cylinder head warp	0.03 mm	
3	Compression pressure	11 to 13 kg/cm ² (170.64 ± 14.22 psi)	
4	Valves: Valve (Tappet) clearance (Inlet & Exhaust) (In cold condition) Valve (Inlet) head thickness Valve (Exhaust) head thickness Valve (Inlet) stem diameter Valve (Exhaust) stem diameter Valve (Exhaust) guide inside diameter Valve spring free length	0.08 - 0.12 mm 0.7 ± 0.15 mm 1.0 ± 0.15 mm 5.45 - 5.51 mm 5.45 - 5.48 mm 5.520 - 5.532 mm 37.5 mm	0.003" to 0.005"
5	Cam & Rocker: Rocker arm inside diameter Rocker shaft diameter Cam height (Inlet) Cam height (Exhaust)	10.015 mm 9.975 - 9.990 mm 30.81 mm 30.44 mm	
6	Camshaft chain length (20 links)	127.00 - 127.48 mm	

SERVICE DATA CHASSIS

Sr. No.	Description	Standard	Remark
7	Cylinder/Piston grouping Cylinder bore Piston diameter Cylinder / Piston clearance	57.000 - 57.015 mm 56.979 - 56.995 mm 0.010 - 0.029 mm	Measure at 7 mm from bottom Use Cylinder & Piston of same group
8	Piston ring Piston ring groove thickness a. Top ring b. Second ring c. Oil Piston ring thickness a. Top ring b. Second ring Piston ring end gap a. Top ring b. Second ring Piston ring gap position Top ring - Towards Exhaust side Second ring - Towards Inlet side Top oil rail - 30° left of Exhaust side Oil expander - Towards Inlet side Bottom oil rail - 30° right of Exhaust side	1.0 mm 1.0 mm 2.0 mm 1.0 mm 1.0 mm 0.2 - 0.45 mm 0.2 - 0.45 mm	
9	Crankshaft runout	0.02 mm	
10	Connecting Rod Big End Play (Axial)	0.15 - 0.35 mm	
11	Clutch assembly Friction plate thickness Pressure plate thickness Clutch spring free length	3.1 - 3.3 mm 1.25 mm 25.5 ± 0.3 mm	

DISMANTLING AND ASSEMBLY OF HANDLE BAR

Handle Bar

Removal:

- Remove the allen bolts (a) fixing the mirrors (LH & RH) and take out the mirrors.
- Remove 4 screws (b) securing handle bar top cover.
- Push the speedometer cable up & lift the handle bar top cover.
- Disconnect the speedometer cable and harness (electrical connections).
- Remove the rubber fitted on head light holder.
- Disconnect the wires connected to this holder.
- Remove the screw along with washer.
- Lift the head light assly.
- Disassemble the handle bar parts in alphabetical order as shown in figure.
- Remove the two screws fixing switches on handle bar for removal of LH & RH switch.
- Remove the handle bar from steering column.
- Disconnect the other end of switch harness & pull the harness up.

Assembly:

- Fix front brake switch into handle bar body.
- Fix RH switch with screw.
- Insert gas control tube into handle bar body & assemble gas control link along with washer. Lock gas control tube with lock clip.
- Fix LH switch with screw.
- Insert front brake inner cable into outer cable & fix front brake lever.
- Insert gear control tube into handle bar body & assemble gear control link along with washer. Lock gear control tube with lock clip.
- Insert clutch inner cable into outer cable & fix clutch lever.
- Fix hand grip to gear control tube & gas control tube.
- Insert the wiring harness & connect connection.
- Fix upper under of gear & gas inner cables into gear & gas control link.
- Fix LH & RH bottom plates.
- Fix head light assembly.
- Fix speedometer in handle bar.
- Assemble handle bar cover on handle bar body with four screw.
- Fix head light rim.

DISMANTLING AND ASSEMBLY OF HANDLE BAR

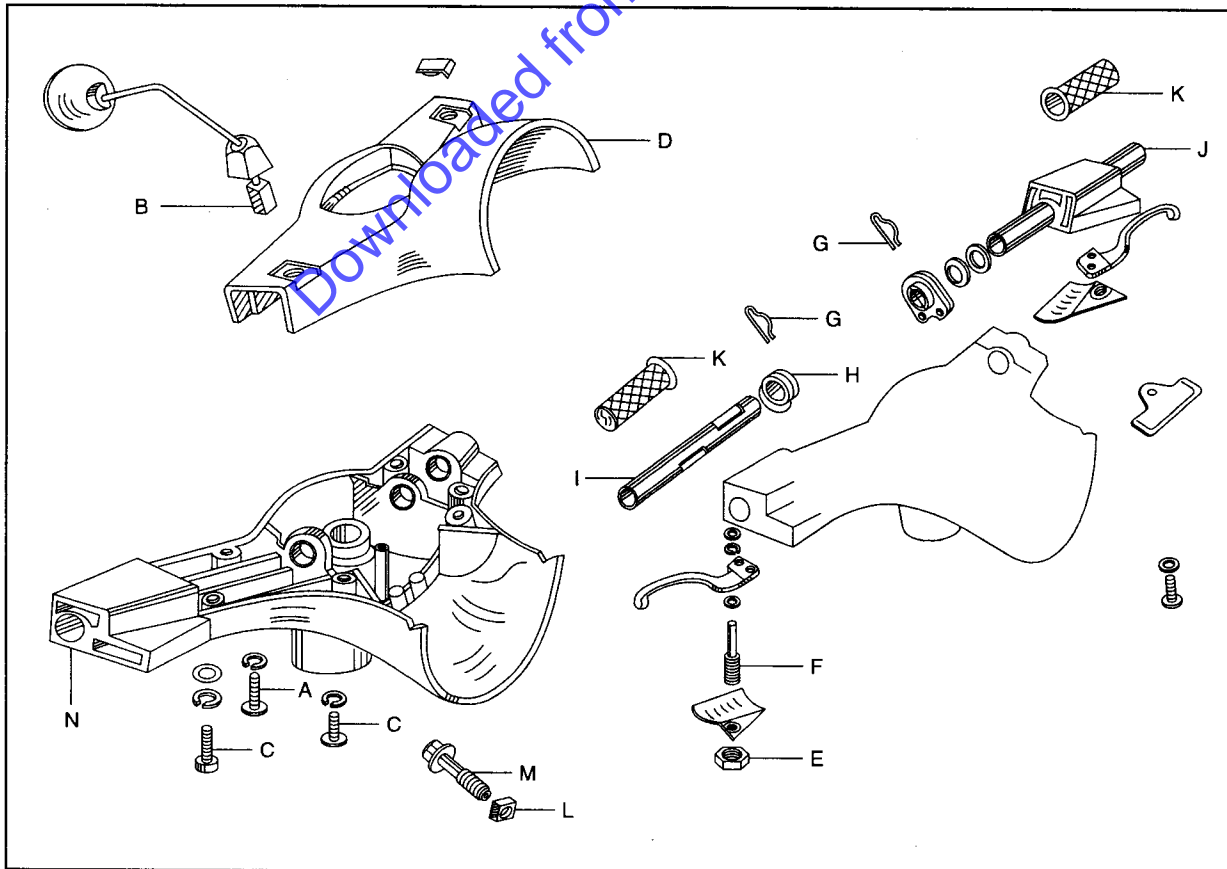

ELECTRICALS : MAINTENANCE & CHECKING

General Precautions:

There are some important precautions to be taken while servicing electrical system. Please follow them.

- Do not reverse the battery lead connections. This will burn out the diodes in the electrical parts.
- Always check battery condition before condemning other parts of an electrical system. A fully charged battery is a must for conducting accurate electrical system tests.
- The electrical parts should never be struck sharply, as with a hammer, or allowed to fall on a hard surface. Such a shock to the parts can damage them.
- To prevent damage to electrical parts, do not disconnect the battery leads or any other electrical connections when the ignition switch is on, or the engine is running.
- Do not use a meter illumination bulb rated for other than the voltage or wattage specified in the wiring diagram, as the meter or gauge panel could be warped by excessive heat radiated from the bulb.
- Take care not to short the leads that are directly connected to the battery positive (+) terminal to the chassis ground.
- Never replace a defective part without determining what CAUSED the failure. If the failure was caused by some other item or items, they too must be repaired or replaced, or the new replacement will soon fall again.
- Make sure all connectors in the circuit are clean and tight, and examine wires for signs of burning, fraying, etc. Poor wires and bad connections will affect electrical system operation.
- Measure coil and winding resistance when the part is at room temperature.
- Colour codes:

Code	Colour	Code	Colour
B	Black	Br	Brown
G	Green	Gr	Grey
L	Blue	Lg	Light Green
O	Orange	R	Red
W	White	Y	Yellow
B/Y	Black/Yellow	R/W	Red/White
L/W	Blue/White	W/G	White/Green
Y/R	Yellow/Red	B/W	Black/White
W/R	White/Red	R/B	Red/Black
R/Y	Red/Yellow		

Throttle Regulated Ignition Control System (TRICS)

In 'TRICS', Ignition timing varies as per throttle opening. Below half throttle, ignition timing changes from 16° to 30° in proportion to engine rpm. Refer graph 1.

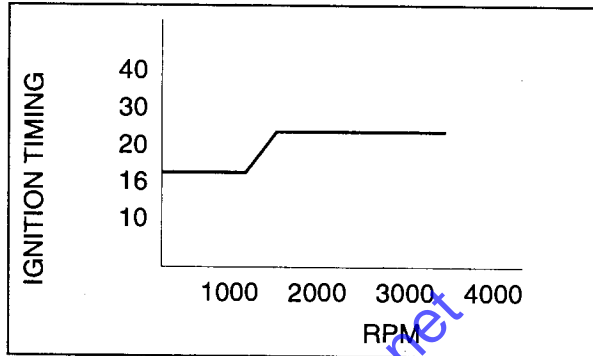

IGNITION TIMING BELOW HALF THROTTLE

After half throttle ignition timing changes to 160 irrespective of engine rpm. Refer graph 2.

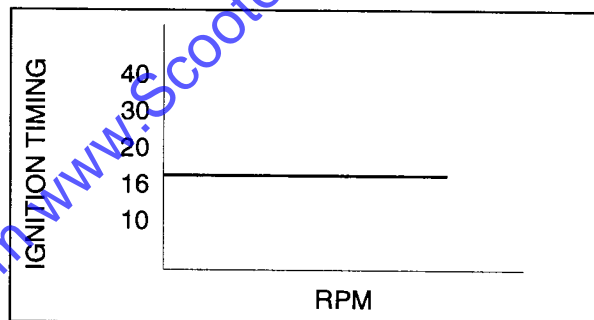

IGNITION TIMING AFTER HALF THROTTLE

Details of modifications in various parts are as under.

A. **Throttle sensor** : Throttle sensor is provided in Handle bar. A signal is passed to C.D.I. Unit with the help of this sensor as per position of throttle.

B. **Gas control link** : Gas control link is modified.

Checking Procedure

Control Switches (For Chetak 4S)

Control switch RH

a) Engine stop switch

Position	Colour	
	Violet	Black
OFF	*	*
ON	●	●

b) Start Switch

Position	Colour	
	Red	Red/Yellow
START	●	●

ELECTRICALS : MAINTENANCE & CHECKING

Control switch LH

a) Side indicator switch

Position	Colour		
	Grey Red	Green White	Blue White
RH	●	●	
N			
LH		●	●

b) Horn Switch

Position	Colour	
	Black	White
ON (Pressed)	●	●
OFF		

b) Deeper Switch

Position	Colour		
	Brown Blue	Red Blue	Violet
Hi	●	●	
Low		●	●

Front & Rear Brake Switches:

Disconnect the two terminals of the front or rear brake switch and connect an ohmmeter between the two terminals setting it on x 10 ohms range. When the switch is pressed the ohmmeter should show infinity and when switch is released the ohmmeter should show 0 ohms.

If not showing above readings replace brake switch.

Range	Connection	Switch position	Reading
x10 ohms	Red	Switch pressed	∞
	Blue	Switch released	0 ohms

Steering cum Ignition Switch

Connect the +ve meter lead to Red cable and -ve meter lead to Black cable. Check continuity (0 ohms) as given below:

Switch position	Black Yellow	Violet	Red White	Red
Ignition OFF (steering lock)	●	●	●	●
Ignition OFF (steering unlock)	●	●	●	●
Ignition ON (steering unlock)	●	●	●	●

H.T. Coil

To measure the H.T. Coil resistance on the vehicle, remove the spark plug cap from spark plug lead and test as per table. Take both reading i.e. primary and secondary with respect to ground.

	Meter	Reading
Primary winding	x 1 ohms	0.9 to 1.1 ohms
Secondary winding	x 1 kohms	6.5 to 7.5 kohms

Coils on Stator Plate Assly

Use the hand tester (37 1030 63) for checking the resistance across the coils.

1. Lighting Coil

First connect the +ve meter lead to Green cable and -ve meter lead to Black (earth). The resistance value should be as tabulated below:

Range	Connection		Reading
	Meter +ve	Meter -ve	
x1 ohms	Green	Black	0.5 to 0.8ohms

2. Charging Coil

First connect the +ve meter lead to Yellow cable and -ve meter lead to Black (earth). The resistance value should be as tabulated below:

Range	Connection		Reading
	Meter +ve	Meter -ve	
x10 ohms	Yellow	Black	245to295ohms

3. Pulser Coil

First connect the +ve meter lead to Grey cable and -ve meter lead to Black (earth). The resistance value should be as tabulated below:

Range	Connection		Reading
	Meter +ve	Meter -ve	
x10 ohms	Grey	Black	108to132ohms

4. Battery Charging Coil

First connect the +ve meter lead to Orange cable and -ve meter lead to Blue/Red. The resistance value should be as tabulated below:

Range	Connection		Reading
	Meter +ve	Meter -ve	
x10 ohms	Orange	Blue/Red	0.65to0.95ohms

ELECTRICALS : MAINTENANCE & CHECKING

5. Insulation Check

To check whether coil body is shorted.

Note: Disconnect wire connected to earth for lighting & charging coil before conducting insulation check.

Range	Connection		Reading
	Meter +ve	Meter -ve	
x10 ohms	Core (Remove varnish from core to have proper contact)	Either one of terminal	>200K ohms

Battery Charging System

- Ensure that battery is fully charged.
- Set meter range at 20 A DC.
- Remove fuse & connect meter +ve lead to other terminal of fuse i.e. Red/White wire coming from D.C. Regulator and meter -ve lead to Red wire coming from battery +ve terminal.
- All D.C. load viz. Brake lights and Side Indicator bulbs are to be switched OFF.
- Start the Engine. Set the Engine RPM at 3500 RPM.
- Measure Battery charging current. It should be 1.0 to 3.0 amps i.e. current must flow into the Battery.

Range	Connection		Reading
	Meter +ve	Meter -ve	
20A DC	Red/White	Red	1.0 to 3.0A

- Stop the Engine. Disconnect the meter and reconnect the fuse.
- As a further check, set meter range at 25 V DC.
- Connect +ve lead of meter to +ve terminals of Battery and -ve terminal of meter to -ve terminal of Battery.
- Ensure that all lights are off.
- Start the Engine.
- As the RPM of engine increases, voltage will also increase. Measure the Battery terminal voltage is 3500 RPM.

Range	Connection		Reading
	Meter +ve	Meter -ve	
25V DC	Battery +ve	Battery +ve	14.7 +- 1 V

Note: Use fully charged Battery (Specific gravity of electrolyte = 1.24)

Turn Signal Relay

Remove the flasher unit which is to be checked and connect it to another vehicle whose flasher unit and side indicators are working properly. Check that the terminals are connected correctly. Start the vehicle and put ON the indicator switch and see if the flasher unit functions or not. If flasher unit works properly then there may be some problem with the switch or regulator or with the wiring of the vehicle whose flasher unit is being checked.

Also check flash rate (No. of flashes/min). If flash rate is not within the specified limit i.e. 90 ± 30 flashes/min. replace it as it is faulty.

Fuel Level Gauge (Tank Unit)

To see the quantity of fuel inside the fuel tank at a glance, a fuel gauge is provided on the instrument panel. The fuel gauge works on the principle of variable resistance.

The fuel gauge works on D.C. supply.

The fuel gauge consists of a float for level sensing a sender for sending the signal and the gauge for converting the signals from sender into the movement of the needle.

Checking of Fuel Tank Unit:

Connection	Tank (float)	Reading
White/Black Meter x10ohms	Fuel (Full) (Highest position)	1.0 to 5.0 ohms
Black	Fuel (Empty) (Lowest position)	103 to 117 ohms

ELECTRICALS : MAINTENANCE & CHECKING

D.C. Horn

1. Tuning of D.C. Horn

- Check the horn sound. If it is weak or feeble, loose the check nut provided at the back of horn.
- With the help of screw driver, rotate the screw till the horn sound is good.
- After proper tune up, hold the screw & lock the check nut.

2. D.C. current measurement

- Remove the Orange wire from Horn & connect one lead of meter to Orange wire and other lead of meter to horn terminal from which Orange wire is removed.
 - Start the engine and set it at 3500 RPM.
 - Press the Horn button.
 - Measure the current at 3500 RPM.

Range	Connection		Reading
	Meter +ve	Meter -ve	
20V DC	Orange	Horn terminal	1.5 A max.

Spark Plug Cap (Resistive)

- Remove H.T. cable from spark plug cap.
- Connect +ve lead of meter to spark plug cap where H.T. cable is connected and -ve lead of meter inside cap where spark plug is fitted.
- Measure the resistance across the spark plug cap.

Range	Connection		Reading
	Meter +ve	Meter -ve	
x1K ohms	Where H.T. cable is connected	Where Spark Plug is fitted	4.0 to 6.5 K ohms

C.D.I. UNIT (With 'TRICS')

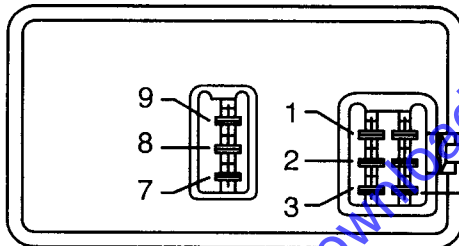

METER RANGE X 10 Ω		METER NEGATIVE (-VE) LEAD CONNECTION							
		1	2	3	4	6	7	8	9
METER POSITIVE (+VE) LEAD CONNECTION	1	∞	∞	40 ~ 60 Ω	∞	∞	∞	0	
	2	250 ~ 400 Ω	40 ~ 60 Ω	∞	∞	∞	∞	250 ~ 400 Ω	
	3	40 ~ 60 Ω		250 ~ 400 Ω	∞	∞	∞	40 ~ 60 Ω	
	4	∞	∞	∞		∞	∞	∞	
	6	∞	∞	∞	∞		∞	∞	
	7	∞	∞	∞	∞	∞		∞	
	8	∞	∞	∞	∞	∞	∞		
	9	0	∞	∞	40 ~ 60 Ω	∞	∞	∞	

For effective overhaul and optimum performance :

- **Get fully familiarised with dismantling / assembly procedures as given in this manual**
- **Always use genuine Bajaj Spares for replacement.**
- **Use special tools developed for disassembling and assembly procedures.**

Downloaded from www.ScooterTime.net